

## Construction of Automatic Phase Selector for the Generation of a Steady Power Supply

Abu Ubaida D Adamu<sup>a\*</sup>, Hamza Mohammed<sup>a</sup> and Kasimu M. Moshud<sup>b</sup>

<sup>a</sup>*Department of Physics Modibbo Adama University Yola, Nigeria.*

<sup>b</sup>*Department of Pure and Applied Physics Federal University Wukari, Taraba State, Nigeria.*

### ARTICLE INFO

#### Article history:

Received 03 May 2025

Received in revised form 10 August 2025

Accepted 20 August 2025

#### Keywords:

Phase selector, automatic system, uninterrupted power, micro controller, transformer.

#### MSC 2020 Subject classification:

93C83, 93C83, 93C95, 78A50

### ABSTRACT

The research on the automatic phase selector primarily focused on developing a highly efficient system capable of maintaining an uninterrupted power supply. Its goals included optimizing power delivery, improving reliability in distribution, enhancing power management efficiency, enabling remote monitoring, and ensuring both safety and regulatory compliance. The device was built upon existing designs found in literature, which were modified to incorporate advanced features such as automatic phase detection and switching, reduced energy loss, improved efficiency, and enhanced power factor correction. Key components used in the construction include a transformer, LM741 operational amplifier/comparator, relay switch, resistors, 100  $\mu$ F 35V electrolytic capacitors, a 10 k $\Omega$  variable resistor (potentiometer), IN4007 diodes, 5.1V zener diodes, a display module, and indicator lights. The design approach was informed by expert technical advice and online research into current models of automatic phase selectors. This device is suitable for a range of uses, including industrial power systems and renewable energy setups, offering a dependable, efficient, and cost-effective solution for contemporary power distribution needs.

## 1. Introduction

Cardiovascular In today's world of electrical engineering and power distribution, achieving both efficiency and reliability is essential. A key device that contributes to these goals is the automatic phase selector, which ensures continuous power supply by automatically switching between available power phases. This functionality is especially critical in settings such as healthcare facilities and other complex systems, where power interruptions can have serious consequences. In the past, phase failure often disrupted operations in industries, offices, and homes leading to situations where some appliances in a building remained on while others turned off, thereby affecting daily routines.

The automatic phase selector was developed to detect available live phases and connect the electrical load to an active one. Some previous designs focused on detecting a single active phase and utilized relays electromechanical switches driven by transistors to connect the load to the live phase. When two or more phases are available, the circuit selects the most stable or suitable one for connection. Certain studies, such

\* Corresponding author. Tel.: +2348136132102

E-mail address: [abudodos1@mau.edu.ng](mailto:abudodos1@mau.edu.ng) (ADAdamu)

<https://doi.org/10.62054/ijdm/0203.12>

as that of Pattewar *et al.* (2017), employed a regulated 12V, 500mA power supply with a 7805 voltage regulator for stabilization. Their design also included a bridge-type full-wave rectifier to convert AC to DC from a 230V/12V step-down transformer.

## 2. Literature Review

The body of research on automatic three-phase selectors covers a wide range of topics including technical specifications, design architecture, performance testing, fault detection strategies, integration with renewable energy sources, remote control functionality, and industrial applications. These devices are essential for ensuring a steady and efficient power supply, especially in systems requiring high reliability. Ofualagba and Udoha (2017) emphasized the use of comparators (e.g., LM741 IC) for phase selection, allowing the system to automatically switch to the phase with the highest voltage, thereby maintaining a stable power supply. These comparators operate in a non-linear mode without feedback, resulting in open-loop voltage gain.

Uchechuku (2015) highlighted that frequent phase failures in the past often led to manual switching of fuses, causing delays and potential damage. Their work introduced an automatic switching mechanism that could transfer loads to a functioning phase during outages and return them once power was restored. The design was tested through electrical continuity checks, conductivity tests, and simulations using Proteus software. Their findings confirmed the importance of automation, especially in regions where manual switching can result in costly human errors.

Vipulatippa *et al.* (2018) pointed out that in the absence of automation, manual switching between power sources (like a generator and the grid) is time-consuming and inefficient. The need for reliable automatic systems becomes more urgent as industries grow more dependent on stable power. Usman (2024) presented an enhanced design for a three-phase automatic selector capable of switching between the grid and generator during outages. This system uses components such as operational amplifiers, timing circuits, and high-current relays powered by a 12V DC supply. It can also shut down the generator once grid power is restored, improving both functionality and energy efficiency. Bawane *et al.* (2013) observed that power cuts are a frequent issue. Their research demonstrated how automatic phase selectors can quickly detect and switch to an available phase within seconds, eliminating the need for backup power and reducing operational delays in commercial and residential settings.

Adedoton *et al.* (2021) addressed Nigeria's unstable power supply caused by growing demand and poor

infrastructure. They developed a microcontroller-based automatic phase selector capable of switching between public utility supply and alternative sources. The system was divided into hardware (including sensors, control circuits, display units, and power electronics) and software (programmed microcontroller logic). Simulations were conducted before physical implementation, followed by testing with real-world utility power systems. Bendre *et al.* (2004) and Short (2018) emphasized that momentary power disturbances, often unrecorded by utilities, can cause significant economic losses in factories due to equipment downtime. Voltage sags, far more frequent than surges, are a major concern, yet their effects are less understood. Devices like programmable logic controllers (PLCs), robots, and motors are particularly susceptible. Mitigating these issues requires either designing more robust equipment or using voltage sag correctors to protect sensitive systems.

Shewale *et al.* (2013) and Jeong *et al.* (2018) discussed how most industrial devices operate on rectified DC from either single-phase or three-phase AC inputs. Poor power factor caused by harmonic distortion is common in such power supplies. In factories, numerous devices depend on single-phase power derived from a three-phase source. Therefore, frequent power disturbances (40–50 annually) often disrupt operations, making automatic phase selection essential. Conrad and Bollen (1997) and Pohjanheimo (2003) highlighted the absence of standardized performance criteria for equipment under voltage sag conditions. As such, equipment remains vulnerable. While ride-through devices can help in the short term, long-term solutions must include standardizing equipment behavior during sags and recovery. Uduma and Arciszewski (2010) pointed out that erratic power supply in many developing countries severely affects equipment performance and user experience. Their research supports automatic switching as a practical solution to maintain constant power without manual intervention. Bridge *et al.* (2018) underscored the role of electricity in national development. Power instability forces reliance on generators, inverters, and solar systems. These alternatives demand efficient switching systems to minimize human involvement and downtime. Oshevire and Amakiri (2021) described a modern automatic three-phase selector that connects load and phases via relay switches. The system can identify outages and seamlessly activate the next available phase. It also prevents the unnecessary starting of a generator, optimizing energy use. Ezema *et al.* (2012) discussed the growing need for robust switching systems due to the increasing use of sensitive electronic equipment in homes, hospitals, and offices. The frequent outages make it necessary to implement faster and more reliable changeover systems.

Akpan *et al.* (2019) described an intelligent automatic phase selector capable of monitoring and comparing three phases to automatically switch to the most viable one. This innovation enhances reliability

and removes the burden of manual intervention. The body of research on automatic three-phase selectors covers a wide range of topics including technical specifications, design architecture, performance testing, fault detection strategies, integration with renewable energy sources, remote control functionality, and industrial applications. These devices are essential for ensuring a steady and efficient power supply, especially in systems requiring high reliability.

Ofualagba and Udoha (2017) emphasized the use of comparators (e.g., LM741 IC) for phase selection, allowing the system to automatically switch to the phase with the highest voltage, thereby maintaining a stable power supply. These comparators operate in a non-linear mode without feedback, resulting in open-loop voltage gain. Uchekuku (2015) highlighted that frequent phase failures in the past often led to manual switching of fuses, causing delays and potential damage. Their work introduced an automatic switching mechanism that could transfer loads to a functioning phase during outages and return them once power was restored. The design was tested through electrical continuity checks, conductivity tests, and simulations using Proteus software. Their findings confirmed the importance of automation, especially in regions where manual switching can result in costly human errors. Vipulatippa *et al.* (2018) pointed out that in the absence of automation, manual switching between power sources (like a generator and the grid) is time-consuming and inefficient. The need for reliable automatic systems becomes more urgent as industries grow more dependent on stable power. Usman (2024) presented an enhanced design for a three-phase automatic selector capable of switching between the grid and generator during outages. This system uses components such as operational amplifiers, timing circuits, and high-current relays powered by a 12V DC supply. It can also shut down the generator once grid power is restored, improving both functionality and energy efficiency.

Bawane *et al.* (2013) observed that power cuts are a frequent issue. Their research demonstrated how automatic phase selectors can quickly detect and switch to an available phase within seconds, eliminating the need for backup power and reducing operational delays in commercial and residential settings. Adedotun *et al.* (2021) addressed Nigeria's unstable power supply caused by growing demand and poor infrastructure. They developed a microcontroller-based automatic phase selector capable of switching between public utility supply and alternative sources. The system was divided into hardware (including sensors, control circuits, display units, and power electronics) and software (programmed microcontroller logic). Simulations were conducted before physical implementation, followed by testing with real-world utility power systems. Bendre *et al.* (2004) and Short (2018) emphasized that momentary power disturbances, often unrecorded by utilities, can cause significant economic losses in factories due to equipment downtime. Voltage sags, far more frequent than surges, are a major concern, yet their effects are less understood.

Devices like programmable logic controllers (PLCs), robots, and motors are particularly susceptible. Mitigating these issues requires either designing more robust equipment or using voltage sag correctors to protect sensitive systems.

Shewale *et al.* (2013) and Jeong *et al.* (2018) discussed how most industrial devices operate on rectified DC from either single-phase or three-phase AC inputs. Poor power factor caused by harmonic distortion is common in such power supplies. In factories, numerous devices depend on single-phase power derived from a three-phase source. Therefore, frequent power disturbances (40–50 annually) often disrupt operations, making automatic phase selection essential. Conrad and Bollen (1997) and Pohjanheimo (2003) highlighted the absence of standardized performance criteria for equipment under voltage sag conditions. As such, equipment remains vulnerable. While ride-through devices can help in the short term, long-term solutions must include standardizing equipment behavior during sags and recovery. Uduma and Arciszewski (2010) pointed out that erratic power supply in many developing countries severely affects equipment performance and user experience. Their research supports automatic switching as a practical solution to maintain constant power without manual intervention. Bridge *et al.* (2018) underscored the role of electricity in national development. Power instability forces reliance on generators, inverters, and solar systems. These alternatives demand efficient switching systems to minimize human involvement and downtime. Oshevire and Amakiri (2021) described a modern automatic three-phase selector that connects load and phases via relay switches. The system can identify outages and seamlessly activate the next available phase. It also prevents the unnecessary starting of a generator, optimizing energy use. Ezema *et al.* (2012) discussed the growing need for robust switching systems due to the increasing use of sensitive electronic equipment in homes, hospitals, and offices. The frequent outages make it necessary to implement faster and more reliable changeover systems. Akpan *et al.* (2019) described an intelligent automatic phase selector capable of monitoring and comparing three phases to automatically switch to the most viable one. This innovation enhances reliability and removes the burden of manual intervention.

### 3. Materials and Method

#### 3.1 Materials

The materials used include; transformer, operational amplifier/comparator (LM741), relay switch resistor, capacitor electrolytic (100 $\mu$ F, 35v), potentiometer (variable resistor 10 k $\Omega$ ), diode-IN4007, zener diode-5.1 V, display module and indicator. The circuit diagram and block diagram of automatic phase selector are presented in Figure 3.1 and Figure 3.2.

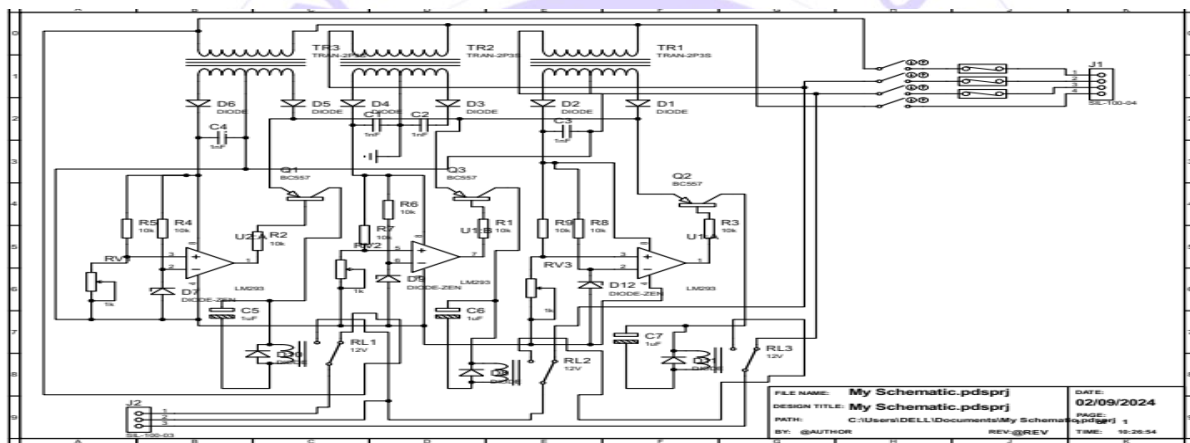

Figure 3.1: circuit diagram

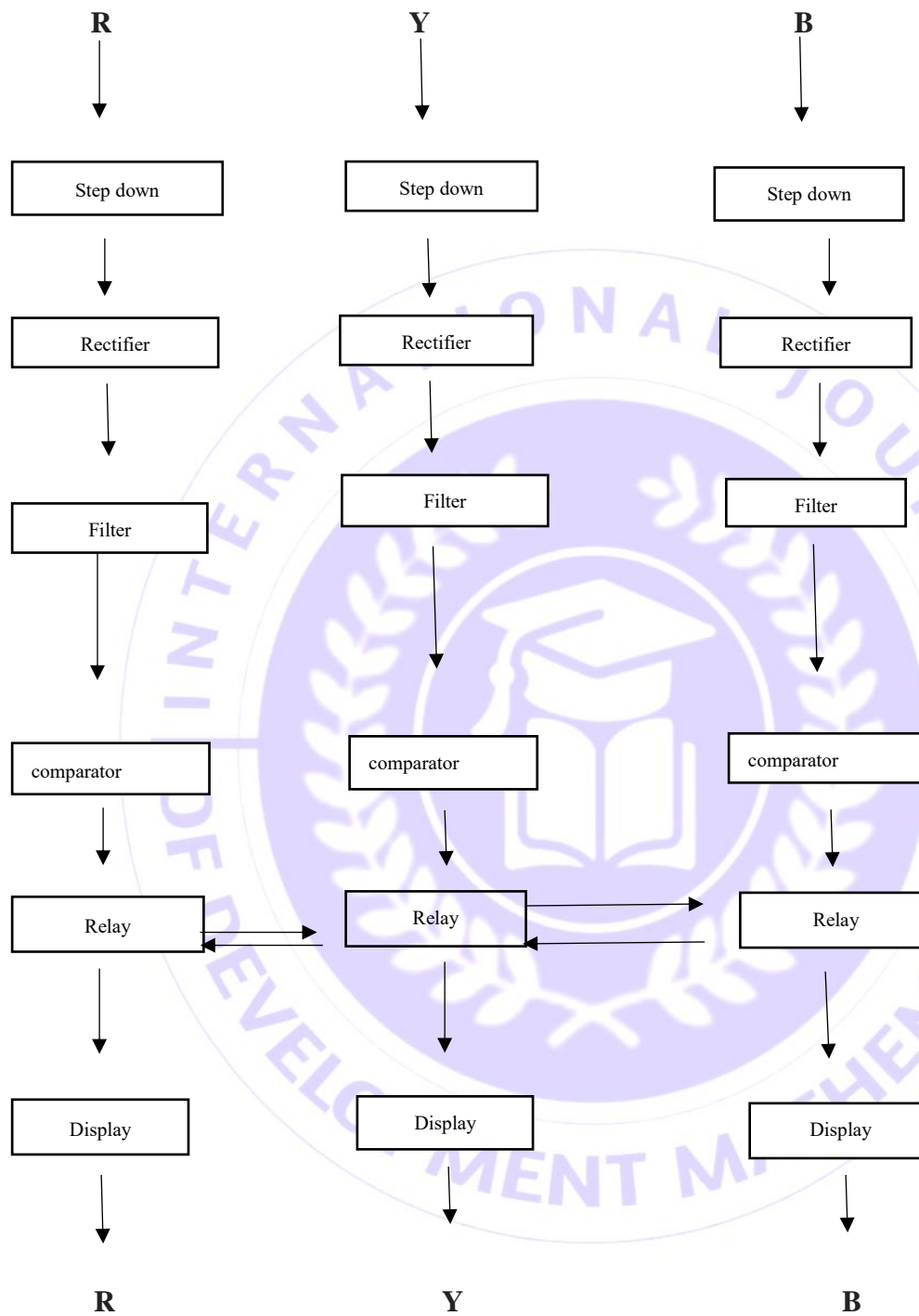

Figure 3.2: Block diagram of automatic phase selector

### 3.2 Methods

A significant amount of information for the research was obtained through consultations with senior colleagues, internet sources, and experienced technologists. The primary sources of information included guidance from technologists and online resources. Recommendations from the technologist regarding specific components to use were carefully adhered to, while online research provided valuable insights into the latest models of automatic phase selectors currently available in the market.

#### 3.2.1 Procedure of the construction

Three identical circuits were constructed—one for each of the three phases. Each circuit was built using a transformer, comparator, transistor, and relay. A step-down transformer was used to reduce the mains voltage, and the LM741 integrated circuit served as the comparator, surrounded by supporting components. The BC557 transistor functioned as a switch, while the relay used was of the electromagnetic type. The entire process was broken down into six key stages: voltage step-down, rectification, filtration, comparison, switching, and display/indication. Each phase supply (R, Y, B) was individually stepped down to the required voltage and current using separate transformers. Only one phase operates at a time. IN4007 diodes were used to convert AC to DC, and capacitors were employed to filter out voltage ripples from the DC supply. Resistors and a potentiometer were used to provide the appropriate input voltage to the comparator. Depending on the comparator's output, the BC557 transistor switched between ON and OFF states, effectively acting as a switch. All components were mounted on a circuit board and wired accordingly. A 12V DC power supply was generated, and the circuit's functionality was verified by connecting a load (a bulb) to the output, which successfully produced the expected result. The casting plate is presented in Plate 3.1.



Plate 3.1: Casting and packaging

### 3.3 Course Implication in Tabular Form

Table 3.1: Breakdown of the items used in this work with their prices

S/No.	Items	Quantity	Unit Price (₦)	Total Price (₦)
1.	Comparator	3	1000	3000
2.	Display Module	1	45000	45000
3.	Diode	9	100	900
4.	Relay Switch	3	1500	4500
5.	Stepdown X-fer	3	7000	21000
6.	Transistor	3	300	900
7.	Variable resistor 10Ω	3	100	300
8.	Zener diode	3	50	150
				Total = 75,750

## 4. Results and Discussion

### 4.1 Continuity Test of the Component

The component was first tested separately to check their working condition and they were found to be good for the work.

Power supply unit

Here a stepdown transformer was used to step down 230 to 12v

Input voltage  $V_i = 230$  V, Output voltage  $V_o = 12$  V, Primary current  $I_p = (1000\text{mA})$ , Transformer current at secondary  $I_s = ?$ .

Using the expression  $I_s = V_p \times I_p / V_s$

where,

$I_s$  = current at secondary,  $V_p$  = voltage at primary,  $I_p$  = current at primary,  $V_s$  = voltage at secondary

To find  $I_s$ ;

$$I_s = 230 \times (1/12) = 19.17 \text{ A}$$

$$V_{\max} = V_{\text{rms}} \times \sqrt{2} = 12 \times \sqrt{2}$$

$$V_{\max} = 12 \times 1.414$$

$$V_{\max} = 16.97 \text{ V}$$

## 5. Conclusion

Automatic phase selector plays a crucial role in optimizing three phase electrical system. By automatically selecting the optimal phase, automatic phase selector minimizes power losses, improves system efficiency, enhanced reliability and reduced maintenance. The beauty of this construction is that it can be used 24hrs and it can neglect a phase with very low voltage

## 6. Recommendation

This work will improve the overall efficiency of our power system in industries, health care system, administrative building and in needed resident. The use of automatic phase selector will protect home appliance from voltage unbalancing. Getting component of the circuit it was a serious problem, I recommend that schools and well doing individuals should provide these components so that to ease this type of work.

## References

- Adedoton, A., et al. (2021). Power Instability and the Need for Alternative Power Sources in Nigeria. *Journal of Energy Systems and Power Engineering*, 12(4), 98-105
- Akpan, E. P., Orike, S., Odeyemi, F. M., & Nkpolu-Oroworukwo, P. H. (2019). An Improved Microcontroller-Based Automatic Three-Phase Analyzer and Selector. *Journal of Newviews in Engineering and Technology (JNET)*, 1(1). <http://www.jnet.org.ng/index.php/jnet/article/view/15>
- Bawane, S., et al. (2013, May 5). Addressing Power Cut Issues with Backup Power Systems. *Journal of Electrical Power Systems and Automation*, 8(2), 120-126.
- Bendre, A., Divan, D., Kranz, W., & Brumsickle, W. (2004, October). Equipment failures caused by power quality disturbances. In *Conference Record of the 2004 IEEE Industry Applications Conference, 2004. 39th IAS Annual Meeting*. (Vol. 1, pp. 207-212). IEEE. <https://doi.org/10.1109/IAS.2004.1348433>

- Bridge, G., Özkaynak, B., & Turhan, E. (2018). Energy infrastructure and the fate of the nation: Introduction to special issue. *Energy Research & Social Science*, 41, 1–11. <https://doi.org/10.1016/j.erss.2018.04.029>
- Conrad, L. E., & Bollen, M. H. J. (1997). Voltage sag coordination for reliable plant operation. *IEEE Transactions on Industry Applications*, 33(6), 1459–1464. <https://doi.org/10.1109/28.649956>
- Ezema, L. S., Peter, B. U., & Harris, O. O. (2012). Design of automatic change over switch with generator control mechanism. *Academic Research International*, 3(3), 125. [www.savap.org.pk/journals](http://www.savap.org.pk/journals)
- Jeong, H., Lee, J., & Kim, S. (2018). Design and Application of Diode Bridge Rectifiers with Capacitor Filters in Power Systems. *Journal of Electrical Engineering and Power Electronics*, 15(3), 145–152. DOI: 10.21203/rs.3.rs-4383150/v1
- Ofualagba, G., & Udoha, E. E. (2017). Design and simulation of automatic phase selector and changeover switch for 3-phase supply. *International Journal of Novel Research in Electrical and Mechanical Engineering*, 4(2), 28–35.  
URL: [https://www.academia.edu/35063926/DESIGN\\_AND\\_SIMULATION\\_OF\\_AUTOMATIC\\_PHASE\\_SELECTOR\\_AND\\_CHANGE\\_OVER\\_SWITCH\\_FOR\\_3\\_PHASE\\_SUPPLY](https://www.academia.edu/35063926/DESIGN_AND_SIMULATION_OF_AUTOMATIC_PHASE_SELECTOR_AND_CHANGE_OVER_SWITCH_FOR_3_PHASE_SUPPLY)
- Oshevire, P., & Amakiri, O. F. (2021). Design and implementing an uninterruptible power supply with a phase selector, automatic change over switch with generator starter. *Nigerian Journal of Scientific Research*, 20(2), 180–190.  
URL  
(viaResearchGate): [https://www.researchgate.net/publication/354449465\\_Design\\_and\\_Implementing\\_an\\_Uninterruptible\\_Power\\_Supply\\_with\\_a\\_Phase\\_Selector\\_Automatic\\_Change\\_over\\_Switch\\_with\\_Generator\\_Starter](https://www.researchgate.net/publication/354449465_Design_and_Implementing_an_Uninterruptible_Power_Supply_with_a_Phase_Selector_Automatic_Change_over_Switch_with_Generator_Starter)
- Pattewar, T. M., Dange, S. S., Dandekar, M. M., & Dandge, S. S. (2017). Automatic active phase selector for single phase load from three phase supply. *International Research Journal of Engineering and Technology (IRJET)*, 4(3), 2044–2048. URL (Direct from IRJET): <https://www.irjet.net/archives/V4/i3/IRJET-V4I3442.pdf>
- Pohjanheimo, P. (2003). *A Probabilistic Method for Comprehensive Voltage Sag Management in Power Distribution Systems*. URL Link: <https://aaltoodoc.aalto.fi/bitstream/handle/123456789/2296/publication5.pdf>
- Shewale, A. M., Date, T. N., & Kushare, B. E. (2013, February). Effect of voltage sag on ageing of front end rectifier diodes of ASD. In *2013 International Conference on Power, Energy and Control (ICPEC)* (550-553). IEEE. DOI Link: <https://doi.org/10.1109/ICPEC.2013.6527731>
- Short, T. A. (2018). Distribution short-circuit protection. In L. L. Grigsby (Ed.), *Electric Power Generation, Transmission, and Distribution* (pp. 30-1). CRC Press. URL: <https://www.routledge.com/Electric-Power-Generation-Transmission-and-Third-Edition/Grigsby/p/book/9781138196623>
- Uchekukwu, O. (2015). Phase selection mechanism in power distribution systems. *Journal of Electrical and Electronic Engineering*, 10(2), 45-51.  
[https://www.researchgate.net/publication/348193235\\_Phase\\_Selection\\_Mechanism\\_in\\_Power\\_Distribution\\_Systems](https://www.researchgate.net/publication/348193235_Phase_Selection_Mechanism_in_Power_Distribution_Systems).
- Uduma, K., & Arciszewski, T. (2010). Sustainable energy development: The key to a stable Nigeria. *Sustainability*, 2(6), 1558–1570. URL: <https://www.mdpi.com/2071-1050/2/6/1558>
- Usman, A. (2024). Automatic power switching system using operational amplifiers and relay switches. *International Journal of Power Systems Engineering*, 15(1), 67–75. <http://www.powerengineeringjournal.com/archive/vol15/issue1/6.pdf>

Vipulatippa, M., Ramesh, K., & Kumar, A. (2018). Design and implementation of automatic phase selector for uninterrupted power supply. *International Journal of Electrical and Electronics Engineering Research (IJEEER)*, 8(3), 15–24. Retrieved from [https://www.ripublication.com/ijeeer18/ijeeerv8n3\\_02.pdf](https://www.ripublication.com/ijeeer18/ijeeerv8n3_02.pdf).

