



INTERNATIONAL JOURNAL OF DEVELOPMENT MATHEMATICS

ISSN: 3026-8656 (Print) | 3026-8699 (Online)

journal homepage: <https://ijdm.org.ng/index.php/Journals>

A Mathematical Model for Newcastle Disease Transmission with Vaccination and Quarantine Implications for Poultry Development

Washachi D. Jacob^{a,*}, Agada A. Andrew^b, Aliyu G. Dzarma^a, Hyacinth O. Ortser^a and Adejoh B. Sunday^a

^aDepartment of Mathematics, Nigerian Army University Biu, Borno State

^bDepartment of Mathematics, Federal University of Technology Ikot Abasi, Akwa Ibom State

ARTICLE INFO

Article history:

Received 02 January 2026

Received in revised form 10 March 2026

Accepted 17 March 2026

Keywords:

Newcastle disease; compartmental modeling; reproduction number; LaSalle's invariance principle; endemic equilibrium

MSC 2020 Subject classification:

34D20

ABSTRACT

Newcastle Disease (ND) is a highly contagious viral infection that poses a serious threat to poultry production worldwide, particularly in developing countries. In this study, a deterministic compartmental mathematical model is developed to investigate the transmission dynamics of Newcastle Disease in a poultry population. The total population is divided into seven epidemiological classes: susceptible, exposed, asymptomatic infectious, symptomatic infectious, quarantined, recovered, and vaccinated birds. The model incorporates key control strategies including vaccination and quarantine. Qualitative analysis of the model is carried out by establishing the disease-free and endemic equilibrium states. The basic reproduction number is derived using the next generation matrix approach and shown to govern the threshold behavior of the disease. Global stability of the disease-free equilibrium is established using a Lyapunov function and LaSalle's invariance principle. Numerical simulations are performed to support the analytical results and to illustrate the effects of different infection seeding scenarios. Peak analysis, bar charts, and heatmaps are used to compare outbreak intensity and timing across compartments. The results show that vaccination and quarantine significantly reduce disease burden and delay outbreak peaks. Effective quarantine can prevent disease invasion even in the presence of infected birds, while inadequate vaccination allows persistence of the disease. The findings provide useful insights for the design of effective control strategies against Newcastle Disease in poultry populations.

1. Introduction

Newcastle Disease (ND) is a highly infectious and economically devastating viral disease that affects domestic and wild avian species, especially poultry. Caused by the avian paramyxovirus type 1 (APMV-1), the disease poses a persistent threat to global poultry production, with outbreaks reported in over 250 species of birds across more than 150 countries (Alexander, 2000; OIE, 2021; Furaha, Gasper & Verdiana, 2019). ND is classified by the World Organization for Animal Health (WOAH) as a notifiable disease, meaning outbreaks must be reported due to its international significance and trade implications (OIE, 2021; Hugo *et al.*, 2016). The virus spreads primarily through direct contact with infected birds and their secretions, including respiratory droplets, feces, and contaminated feed or water. Indirect transmission occurs via fomites such as equipment, clothing, vehicles, and even through airborne

*Corresponding author. Tel.: +2348066804528

E-mail address: washachidekera@naub.edu.ng (Jacob, W. D.)

<https://doi.org/10.62054/ijdm/0301.08>

particles in densely populated poultry houses (Miller *et al.*, 2013; Komwihangilo, 2016). The virus can survive in the environment for several weeks, particularly in colder climates, making biosecurity challenging in both commercial and backyard farms (Susta *et al.*, 2011; Alexander, Manvell, & Lowings, 1997). Epidemiological Burden and Socioeconomic Impact ND causes high morbidity and mortality rates, often reaching 100% in unvaccinated flocks infected with virulent strains (Diel *et al.*, 2012). In Nigeria alone, ND is responsible for up to 70% of poultry deaths annually, with an estimated ₦2.160 billion in economic losses reported across sub-Saharan Africa due to flock destruction, reduced egg production, and trade restrictions (Adene & Oguntade, 2006). Thousands of smallholder farmers have lost entire flocks to ND outbreaks, leading to severe food insecurity and loss of livelihood, especially among women and low-income households that rely on poultry for income and nutrition (Dinka *et al.*, 2010). Infected birds exhibit a wide range of clinical signs depending on the strain and host species. These include respiratory distress, greenish diarrhea, neurological signs such as tremors and paralysis, and sudden death. ND presents in different forms lentogenic (mild), mesogenic (moderate), and velogenic (highly virulent) with the velogenic strain causing severe disease and rapid spread (Kapczynski & King, 2005). There is no specific antiviral treatment for ND; management is primarily supportive, including hydration, nutrition, and isolation of infected birds. Recovery is possible in some cases, with survivors developing lifelong immunity, though productivity (e.g., egg laying) is often permanently reduced (OIE, 2021). Vaccination is the most effective prevention strategy, and multiple live and inactivated ND vaccines are widely used. However, gaps in vaccine coverage, poor cold-chain management, and antigenic variation of the virus can reduce vaccine efficacy (Miller *et al.*, 2013). Comprehensive biosecurity measures, including quarantine, disinfection, restriction of movement, and surveillance, are essential to reduce transmission. Mathematical models that simulate the dynamics of ND under various intervention strategies are increasingly used to inform decision-making and optimize resource allocation (Yusuf *et al.*, 2020). This study proposes a compartmental model to analyze the transmission dynamics of ND using seven key states of infection: Vaccinated, Susceptible, Exposed, Infectious Asymptomatic, Infectious Symptomatic, Quarantined, and Recovered. By modeling transitions between these compartments, we aim to understand how vaccination, quarantine, and recovery impact disease spread and control. The insights generated can guide policy formulation and practical interventions to reduce the economic and epidemiological burden of ND in poultry systems.

2. Methodology

2.1 Model Formulation

Assumptions

- i. Birds enter the susceptible class through recruitment at a constant rate $(1 - b)\Lambda$.
- ii. Vaccination occurs at rate $b\Lambda$ for newborns and (ρ) for susceptible birds.
- iii. Infection occurs via contact between susceptible and infectious birds (both asymptomatic and symptomatic).
- iv. Vaccination is not fully protective

- v. Exposed birds are not infectious
- vi. Both asymptomatic and symptomatic birds transmit the disease
- vii. Recovered birds may still be culled
- viii. Quarantine reduces but does not eliminate transmission

2.2 Model descriptions

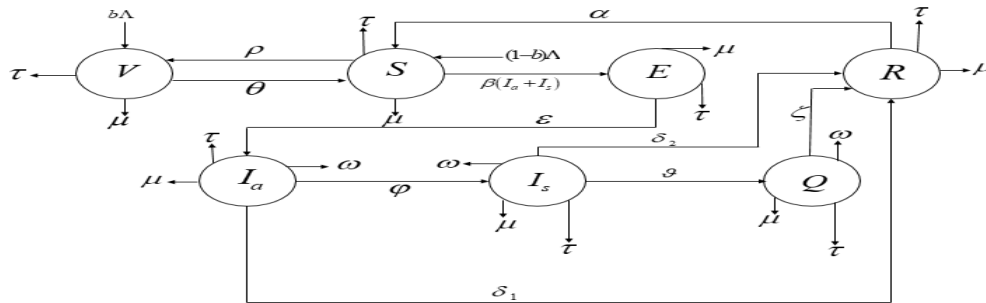

Figure 1: Schematic diagram of the model

The model consists of seven birds compartments namely: Vaccinated birds $V(t)$, susceptible birds $S(t)$, exposed birds $E(t)$, Asymptomatic birds $I_a(t)$, symptomatic birds $I_s(t)$, quarantine $Q(t)$ and recovered birds $R(t)$. One unique thing about the model is that each compartment suffers both natural death and the culling rate at the time t . Culling Vaccinated birds $V(t)$, susceptible birds $S(t)$ and exposed $E(t)$ birds helps eliminate potential sources of infection. Culling Asymptomatic birds $I_a(t)$ symptomatic birds $I_s(t)$ controls disease transmission. Culling in the recovery birds $R(t)$ represent birds that do not return to the flock even after recovery due to reduce productivity or risk of carrier state. Both Asymptomatic birds $I_a(t)$, symptomatic birds $I_s(t)$ and quarantine $Q(t)$ suffers induce death at the rate ω . The recruitment into the vaccinated compartment is at the rate $b\Lambda$, The vaccinated birds increase at the rates $(b\Lambda + \rho)$, ρ is the rate at which the susceptible birds are vaccinated and decreases at the rates $(\tau + \mu + \theta)$, where θ is the waning of the vaccine. The susceptible $S(t)$ increases at the rates $((1-b)\Lambda + \alpha + \theta)$ and decreases at the rates $(\tau + \mu + \beta(I_a + I_s) + \rho)$, $\beta(I_a + I_s)$ is the force of infection and β is the sufficient contact rate. The exposed birds $E(t)$ increase due to the contact with the force of infection $\beta(I_a + I_s)$ and decreases at the rates $(\mu + \tau + \varepsilon)$, ε is the progression from exposed $E(t)$ to the asymptomatic birds $I_a(t)$. The symptomatic $I_a(t)$ increase at the rate ε and reduces at the rates $(\tau + \mu + \omega + \varphi + \delta_1)$, φ is the progression from asymptomatic to symptomatic and δ_1 Natural/spontaneous recovery of the asymptomatic birds. The symptomatic birds $I_s(t)$ increase at the rate φ and decreases at the rates $(\tau + \mu + \omega + \delta_2 + \vartheta)$, δ_2 is the recovery through intervention or immune response of symptomatic and ϑ is the rate of progression from symptomatic to quarantine birds. The quarantine $Q(t)$ increase at a rate ϑ and decreases at the rates $(\tau + \mu + \omega + \zeta)$, ζ is the rate at which

quarantine birds recovered due to treatment. The recovery $R(t)$ increase at the rate $(\delta_1 + \delta_2 + \zeta)$ and decreases at the rates $(\mu + \alpha + \tau)$.

2.2 Equations of the model

$$\left. \begin{aligned} \frac{dV}{dt} &= b\Lambda + \rho S - (\tau + \theta + \mu)V \\ \frac{dS}{dt} &= (1-b)\Lambda + \alpha R + \theta V - (\tau + \mu + \rho + \beta(I_a + I_s))S \\ \frac{dE}{dt} &= \beta(I_a + I_s)S - (\tau + \mu + \varepsilon)E \\ \frac{dI_a}{dt} &= \varepsilon E - (\tau + \omega + \mu + \varphi + \delta_1)I_a \\ \frac{dI_s}{dt} &= \varphi I_a - (\tau + \omega + \vartheta + \delta_2 + \mu)I_s \\ \frac{dQ}{dt} &= \vartheta I_s - (\zeta + \tau + \omega + \mu)Q \\ \frac{dR}{dt} &= \delta_1 I_a + \delta_2 I_s + \zeta Q - (\tau + \alpha + \mu)R \end{aligned} \right\} \quad (1)$$

with the following initial conditions

$$V > 0, S > 0, E > 0, I_a \geq 0, I_s \geq 0, Q \geq 0, R > 0$$

Table 1: Description of state variables/parameters of the model

Variables/parameters	Description
V -Vaccinated	Birds that received ND vaccine and are protected at time t.
S -Susceptible	Birds not yet exposed to ND, but can become infected at time t.
E -exposed	Birds exposed to ND virus but not yet infectious (latent period) at time t.
I_a - Infectious Asymptomatic	Birds that carry the virus and can spread it, but show no symptoms at time t.
I_s - Infectious symptomatic	Birds that are visibly sick and infectious at time t.
Q -quarantined	Infected birds isolated to prevent further spread at time t
R - Recovery	Birds that survived ND infection and gained natural immunity at time t.
$b\Lambda$	Recruitment rate of vaccinated birds at time t
$(1-b)\Lambda$	Recruitment rate of susceptible birds at time t
μ	Natural death rate of the birds at time t
τ	Culling of birds from a flock due to disease, sell, poor

ρ	productivity or age at time t. The rate of the vaccination of the susceptible birds at time t
θ	Rate at which immunity wanes in vaccinated birds at time t.
α	Rate at which recovered chickens lose immunity at time t
$\frac{\beta}{\varepsilon} (I_a + I_s)$	Transmission rate at time t Force of infection at time t
ω	Rate at which incubation leads to asymptomatic infection at time t
φ	Induced death rate in each bird populations at time t.
δ_1	The rate of progression from asymptomatic to symptomatic (developing of symptoms) birds at time t.
δ_2	Natural/spontaneous recovery of the asymptomatic birds at time t
\mathcal{G}	The rate of recovery through intervention or immune response of symptomatic birds at time t.
ζ	The rate of progression from symptomatic to quarantine birds for treatment at time t.
	The rate at which quarantine birds recovered due to treatment at time t.

3. Analysis of the Newcastle disease Model

The result below guarantee that the Newcastle disease is governed by the system (1) is epidemiologically and mathematically well-posed in a feasible Region given by:

$$S_0 = \left\{ \begin{array}{l} \{V, S, E, I_a, I_s, Q, R\} \in \mathfrak{R}_+^7, V > S > E \geq 0, I_a \geq 0, \\ I_s \geq 0, Q \geq 0, R \geq 0, \mathbb{N}_{(t)} \leq \frac{\Lambda}{\mu} + \left(\mu_0 - \frac{\Lambda}{\mu} \right) e^{\mu t} \end{array} \right\}$$

3.1 Positivity of Model Solution

For model (1), it is necessary to show that all the state variables are positive, so that the solutions of the model with positive initial conditions remain positive for all $t > 0$. Thus, the following lemma is established.

Lemma 3.1. If the initial data $L(0) > 0$, where

$$L(t) = (V, S, E, I_a, I_s, Q, R). \text{ Then the solution } L(t) \text{ of the model (1) will remain positive for all } t > 0$$

Proof. This lemma is prove using the method of contradiction, first we assume that there exists a time t_1 such that

$$V(t_1) = 0, \frac{dV(t_1)}{dt} < 0, S(t) > 0, E(t) > 0, I_a(t) > 0, I_s(t) > 0, Q(t) > 0, R(t) > 0, 0 < t < t_1. \quad (3.1)$$

There exists a time t_2 such that

$$S(t_2) = 0, \frac{dS(t_2)}{dt} < 0, V(t) > 0, E(t) > 0, I_a(t) > 0, I_s(t) > 0, Q(t) > 0, R(t) > 0, 0 < t < t_2. \quad (3.2)$$

There exists a time t_3 such that

$$E(t_3) = 0, \frac{dE(t_3)}{dt} < 0, V(t) > 0, S(t) > 0, I_a(t) > 0, I_s(t) > 0, Q(t) > 0, R(t) > 0, 0 < t < t_3. \quad (3.3)$$

There exists a time t_4 such that

$$I_a(t_4) = 0, \frac{dI_a(t_4)}{dt} < 0, V(t) > 0, S(t) > 0, E(t) > 0, I_s(t) > 0, Q(t) > 0, R(t) > 0, 0 < t < t_4. \quad (3.4)$$

There exists a time t_5 such that

$$I_s(t_5) = 0, \frac{dI_s(t_5)}{dt} < 0, V(t) > 0, S(t) > 0, E(t) > 0, I_a(t) > 0, Q(t) > 0, R(t) > 0, 0 < t < t_5. \quad (3.5)$$

There exists a time t_6 such that

$$Q(t_6) = 0, \frac{dQ(t_6)}{dt} < 0, V(t) > 0, S(t) > 0, E(t) > 0, I_a(t) > 0, I_s(t) > 0, R(t) > 0, 0 < t < t_6. \quad (3.6)$$

There exists a time t_7 such that

$$R(t_7) = 0, \frac{dR(t_7)}{dt} < 0, V(t) > 0, S(t) > 0, E(t) > 0, I_a(t) > 0, I_s(t) > 0, Q(t) > 0, 0 < t < t_7. \quad (3.7)$$

Applying the assumption in equation (3.1) in the first equation of model (1) we have

$$\frac{dV(t_1)}{dt} = b\Lambda + \rho S > 0$$

this contradict the assumption in equation (3.1) that $\frac{dV(t_1)}{dt} < 0$. $V(t) > 0$ for $t > 0$ Similarly, applying the

assumption in equation (3.2) in the second equation of model (1) we have

$$\frac{dS(t_2)}{dt} = (1-b)\Lambda + \alpha R + \theta V > 0, \text{ this again contradict the assumption in equation (3.2) that}$$

$$\frac{dS(t_2)}{dt} < 0. \text{ Thus, } S(t) > 0 \text{ for } t > 0. \text{ Using similar approach it can be shown that}$$

$E(t) > 0, I_a(t) > 0, I_s(t) > 0, Q(t) > 0$ and $R(t) > 0$ for all $t > 0$. Therefore, the solution $L(t)$, of the model (1) will remain positive for all $t > 0$.

3.2 the disease-free equilibrium of the Newcastle disease

At Newcastle disease (ND)-free $E = I_a = I_s = Q = 0$. The model (1) has an ND -free equilibrium point, given by

$$\Xi_0 = (V^0, S^0, E^0, I_a^0, I_s^0, Q^0, R^0) = \left(\left(\frac{\Lambda(-\rho + b\rho - bA_2)}{\theta\rho - A_1A_2} \right), \left(\frac{\Lambda(\rho A_1 - b\theta\rho - \rho bA_1 + 2bA_1A_2)}{P(\theta\rho - A_1A_2)} \right), 0, 0, 0, 0, 0 \right) \quad (3.8)$$

where $A_1 = (\tau + \theta + \mu)$, $A_2 = (\tau + \mu + \rho)$

and the ND endemic point, given as

$$\begin{aligned} V &= \frac{1}{A_1} \left(b\Lambda + \left\{ \frac{(\Lambda A_4 A_1 A_7 + \alpha A_4 A_1 \zeta \left(\frac{\partial I_a}{\partial \tau} \right) + \alpha \varepsilon \delta_1 EA_1 + \alpha \varphi \delta_2 I_a A_4 + V\theta A_4 A_1 A_7 - b\Lambda A_4 A_1 A_7)}{A_2 A_4 A_1 A_7 + \beta \varepsilon EA_1 A_7 + \beta \varphi I_a A_4 A_7} \right\} \rho \right) \\ S &= \left\{ \frac{(\Lambda A_4 A_1 A_7 + \alpha A_4 A_1 \zeta \left(\frac{\partial I_a}{\partial \tau} \right) + \alpha \varepsilon \delta_1 EA_1 + \alpha \varphi \delta_2 I_a A_4 + V\theta A_4 A_1 A_7 - b\Lambda A_4 A_1 A_7)}{A_2 A_4 A_1 A_7 + \beta \varepsilon EA_1 A_7 + \beta \varphi I_a A_4 A_7} \right\} \\ E &= \frac{(\Lambda A_4 A_1 A_7 + \alpha A_4 A_1 \zeta \left(\frac{\partial I_a}{\partial \tau} \right) + \alpha \varepsilon \delta_1 EA_1 + \alpha \varphi \delta_2 I_a A_4 + V\theta A_4 A_1 A_7 - b\Lambda A_4 A_1 A_7) (\beta \varepsilon EA_1 + \beta \varphi I_a A_4)}{(A_2 A_4 A_1 A_7 + \beta \varepsilon EA_1 A_7 + \beta \varphi I_a A_4 A_7) A_2 A_4 A_1} \\ I_a &= \left\{ \frac{\varepsilon (\beta \varepsilon EA_1 + \beta \varphi I_a A_4) (\Lambda A_4 A_1 A_7 + \alpha A_4 A_1 \zeta \left(\frac{\partial I_a}{\partial \tau} \right) + \alpha \varepsilon \delta_1 EA_1 + \alpha \varphi \delta_2 I_a A_4 + V\theta A_4 A_1 A_7 - b\Lambda A_4 A_1 A_7) A_4}{(A_2 A_4 A_1 A_7 + \beta \varepsilon EA_1 A_7 + \beta \varphi I_a A_4 A_7) A_2 A_4 A_1} \right\} \\ I_s &= \left\{ \frac{\varepsilon \varphi (\beta \varepsilon EA_1 + \beta \varphi I_a A_4) (\Lambda A_4 A_1 A_7 + \alpha A_4 A_1 \zeta \left(\frac{\partial I_a}{\partial \tau} \right) + \alpha \varepsilon \delta_1 EA_1 + \alpha \varphi \delta_2 I_a A_4 + V\theta A_4 A_1 A_7 - b\Lambda A_4 A_1 A_7) A_4}{(A_2 A_4 A_1 A_7 + \beta \varepsilon EA_1 A_7 + \beta \varphi I_a A_4 A_7) A_2 A_4 A_1 A_1} \right\} \\ Q &= \left\{ \frac{(\varepsilon \varphi (\beta \varepsilon EA_1 + \beta \varphi I_a A_4) (\Lambda A_4 A_1 A_7 + \alpha A_4 A_1 \zeta \left(\frac{\partial I_a}{\partial \tau} \right) + \alpha \varepsilon \delta_1 EA_1 + \alpha \varphi \delta_2 I_a A_4 + V\theta A_4 A_1 A_7 - b\Lambda A_4 A_1 A_7) A_4) \partial I_s}{(A_2 A_4 A_1 A_7 + \beta \varepsilon EA_1 A_7 + \beta \varphi I_a A_4 A_7) A_2 A_4 A_1 A_1 A_1} \right\} \\ R &= \frac{(A_4 A_1 \zeta \left(\frac{\partial I_a}{\partial \tau} \right) + \alpha \varepsilon \delta_1 EA_1 + \alpha \varphi \delta_2 I_a A_4)}{A_4 A_1 A_7} \end{aligned}$$

Where

$$\begin{aligned} A_1 &= (\tau + \theta + \mu), A_2 = (\tau + \mu + \rho), A_3 = (\tau + \mu + \varepsilon), \\ A_4 &= (\tau + \mu + \omega + \varphi + \delta_1), A_5 = (\tau + \mu + \omega + \vartheta + \delta_2), \\ A_6 &= (\tau + \mu + \omega + \zeta), A_7 = (\tau + \mu + \alpha) \end{aligned}$$

3.3 Basic Reproduction Number

Basic Reproduction Number is define as the average number of new infections caused by one infectious bird introduced into a completely susceptible bird population, in the absence of any control measures (such as vaccination, culling, or movement restriction).

Evaluating equation (1) at ND-free we have

$$V = \begin{bmatrix} A_3 & 0 & 0 & 0 \\ -\varepsilon & A_4 & 0 & 0 \\ 0 & -\varphi & A_5 & 0 \\ 0 & 0 & -\varrho & A_6 \end{bmatrix}$$

$$A_3 = V_1 = (\tau + \mu + \varepsilon), A_4 = (\tau + \omega + \mu + \varphi + \delta_1), \quad (3.9)$$

$$A_5 = V_3 = (\tau + \omega + \varrho + \delta_2 + \mu), A_6 = (\zeta + \tau + \omega + \mu)$$

Solving (3.9) we have

$$V^{-1} = \begin{bmatrix} \frac{1}{A_3} & 0 & 0 & 0 \\ \frac{\varepsilon}{A_3 A_4} & \frac{1}{A_4} & 0 & 0 \\ \frac{\varepsilon \varphi}{A_3 A_4 A_5} & \frac{\varphi}{A_4 A_5} & \frac{1}{A_5} & 0 \\ \frac{\varepsilon \varrho \varphi}{A_3 A_4 A_5 A_6} & \frac{\varrho \varphi}{A_4 A_5 A_6} & \frac{\varrho}{A_4 A_5 A_6} & \frac{1}{A_6} \end{bmatrix} \quad (3.10)$$

$$A_4 = V_2 = (\tau + \omega + \mu + \varphi + \delta_1), A_6 = (\zeta + \tau + \omega + \mu)$$

$$R_0 = S^0 \beta \varepsilon \frac{(\varphi + \tau + \omega + \varrho + \delta_2 + \mu)}{(\tau + \omega + \mu + \varphi + \delta_1)(\tau + \mu + \varepsilon)(\tau + \omega + \varrho + \delta_2 + \mu)}$$

$$R_0 = S^0 \beta \left(\frac{\varepsilon}{V_1 V_2} + \frac{\varepsilon \varphi}{V_1 V_2 V_3} \right) = \frac{S^0 \beta \varepsilon}{V_1 V_2} \left(1 + \frac{\varphi}{V_3} \right)$$

$\frac{\varepsilon}{V_1}$ is the fraction of exposed that progress to infectious, $\frac{1}{V_2}$ is the mean time an I_a individual remains infectious,

and the bracket accounts for extra infections produced after progression $I_a \rightarrow I_s$ via φ and mean time $\frac{1}{V_3}$.

3.4 Global Stability Analysis of Newcastle virus free Equilibrium

To investigate whether effective control of Newcastle virus free in a given population is independent of the initial data of the populations of the model (1), it is essential to show that the Newcastle virus free equilibrium is globally-asymptotically stable (GAS).

Theorem 3.1. The NCV-free, equilibrium point of the model (1), is GAS in the region \mathbb{Z} .

Proof: let $\beta = 0$, So that the Newcastle virus free equilibrium point exists. Consider the following candidate

Lyapunov function $\mathbb{Q}(t) = k_1 E + k_2 I_a + k_3 I_s + k_4 Q$. Where k_i ($i = 1, 2, \dots, 4$) are some positive constants to be

determined. The corresponding Lyapunov derivative along the solution of model (1) is given by $\dot{\mathbb{Q}}(t)$ (where a dot

represents differentiation with respect to time t). $\dot{\mathbb{Q}}(t) = k_1 \dot{E} + k_2 \dot{I}_a + k_3 \dot{I}_s + k_4 \dot{Q}$ (3.11)

Substituting the RHS of model (1) in equation (3.11) we obtain

$$\begin{aligned} \dot{\mathbb{Q}}(t) &= k_1 \dot{E} + k_2 \dot{I}_a + k_3 \dot{I}_s + k_4 \dot{Q} \\ \dot{\mathbb{Q}}(t) &= k_1 [\beta(I_a + I_s)S - (\tau + \mu + \varepsilon)E] + k_2 [\varepsilon E - (\tau + \omega + \mu + \varphi + \delta_1)I_a] + \\ & k_3 [\varphi I_a - (\tau + \omega + \vartheta + \delta_2 + \mu)I_s] + k_4 [\vartheta I_s - (\zeta + \tau + \omega + \mu)Q] \end{aligned} \quad (3.12)$$

Choosing $k_1 = k_2 = k_3 = k_4 = 1$

and using them in equation (3.12) the following is obtain

$$\dot{\mathbb{Q}}(t) = \beta(I_a + I_s)S - (\tau + \mu)E - (\tau + \omega + \mu + \delta_1)I_a - (\tau + \omega + \delta_2 + \mu)I_s - (\zeta + \tau + \omega + \mu)Q \quad (3.13)$$

Using the following results in equation (3.13)

$$S \leq \frac{\Lambda(\rho A_1 - b\theta\rho - \rho b A_1 + 2b A_1 A_2)}{P(\theta\rho - A_1 A_2)} \quad (3.14)$$

Since $\beta = 0$, then equation (3.13) reduces to

$$\dot{\mathbb{Q}}(t) \leq -(\tau + \mu)E - (\tau + \omega + \mu + \delta_1)I_a - (\tau + \omega + \delta_2 + \mu)I_s - (\zeta + \tau + \omega + \mu)Q \quad (3.9)$$

Therefore, since all the model parameters are positives then $\dot{\mathbb{Q}}(t) \leq 0$ and $\mathbb{Q}(t) = 0$ provided

$$E = I_a = I_s = Q = 0$$

Thus, it follows from LaSalle's in-variance principle in LaSalle, (1976) that the maximal invariant set contained in the region \mathbb{Z} is the singleton Ξ_0 . Hence, the Newcastle disease free equilibrium point is GAS in \mathbb{Z} .

Global stability analysis of Newcastle- endemic equilibrium

Consider the following quadratic Lyapunov function:

$$\dagger(K) = \frac{1}{2} \left[(V - V^*) + (S - S^*) + (E - E^*) + (I_a - I_a^*) + (I_s - I_s^*) + (Q - Q^*) + (R - R^*) \right]^2 \quad (3.14)$$

Where $K = (V, S, E, I_a, I_s, Q, R)$. The Lyapunov derivative with respect to time is

$$\begin{aligned} \frac{d\dagger}{dt} &= \left[(V - V^*) + (S - S^*) + (E - E^*) + (I_a - I_a^*) + (I_s - I_s^*) + (Q - Q^*) + (R - R^*) \right] \\ &\times \left[\frac{d(V + S + E + I_a + I_s + Q + R)}{dt} \right] + (V - V^*) \frac{dV}{dt} \end{aligned} \quad (3.15)$$

According to model (1), it is implied that

$$\begin{aligned} &\frac{d(V + S + E + I_a + I_s + Q + R)}{dt} \\ &= \Lambda - (V + S + E + I_a + I_s + Q + R)(\tau + \mu) - \omega I_a - \omega I_s - \omega Q \end{aligned} \quad (3.16)$$

Substituting equation (3.16) into equation (3.15) yield

$$\begin{aligned} \frac{d\dagger}{dt} &= \left[(V - V^*) + (S - S^*) + (E - E^*) + (I_a - I_a^*) + (I_s - I_s^*) + (Q - Q^*) + (R - R^*) \right] \\ &\times \left[\Lambda - (V + S + E + I_a + I_s + Q + R)(\tau + \mu) - \omega I_a - \omega I_s - \omega Q \right] \end{aligned} \quad (3.17)$$

It can be established from model (1) that, at the endemic steady state

$$\Lambda = (V^* + S^* + E^* + I_a^* + I_s^* + Q^* + R^*)(\tau + \mu) + \omega I_a^* + \omega I_s^* + \omega Q^* \quad (3.18)$$

Substituting equation (3.18) into equation (3.17) produce

$$\begin{aligned} \frac{d\dagger}{dt} &= \left[(V - V^*) + (S - S^*) + (E - E^*) + (I_a - I_a^*) + (I_s - I_s^*) + (Q - Q^*) + (R - R^*) \right] \\ &\times \left[\begin{aligned} &(\tau + \mu)(V^* + S^* + E^* + I_a^* + I_s^* + Q^* + R^*) + \omega I_a^* + \omega I_s^* + \omega Q^* \\ &-(\tau + \mu)(V + S + E + I_a + I_s + Q + R) - \omega I_a - \omega I_s - \omega Q \end{aligned} \right] \end{aligned} \quad (3.19)$$

Simplifying equation (3.19) reduces to

$$\begin{aligned} \frac{d\dagger}{dt} &= \left[(V - V^*) + (S - S^*) + (E - E^*) + (I_a - I_a^*) + (I_s - I_s^*) + (Q - Q^*) + (R - R^*) \right] \\ &\times \left[\begin{aligned} &-(\tau + \mu)(V - V^*) - (\tau + \mu)(S - S^*) - (\tau + \mu)(E - E^*) \\ &-(\tau + \mu)(I_a - I_a^*) - (\tau + \mu)(I_s - I_s^*) - (\tau + \mu)(Q - Q^*) \\ &-(\tau + \mu)(R - R^*) - \omega(I_a - I_a^*) - \omega(I_s - I_s^*) - \omega(Q - Q^*) \end{aligned} \right] \end{aligned} \quad (3.20)$$

Expanding equation (3.20) yield

$$\begin{aligned}
\frac{d\ddagger}{dt} = & -(\tau + \mu)(V - V^*)^2 - (\tau + \mu)(S - S^*)^2 - (\tau + \mu)(E - E^*)^2 \\
& -(\tau + \mu + \omega)(I_a - I_a^*)^2 - (\tau + \mu + \omega)(I_s - I_s^*)^2 \\
& -(\tau + \mu + \omega)(Q - Q^*)^2 - (\tau + \mu + \omega)(R - R^*)^2 \\
& -(2\tau + 2\mu) \times (V - V^*)(S - S^*)(E - E^*)(R - R^*) \\
& -(2\tau + 2\mu + \omega) \times (I_a - I_a^*)(I_s - I_s^*)(Q - Q^*).
\end{aligned} \tag{3.21}$$

Since $V \leq V^*, S \leq S^*, E \leq E^*, I_a \leq I_a^*, I_s \leq I_s^*, Q \leq Q^*, R \leq R^*$,

And then $\frac{d\ddagger}{dt} \leq 0$ in equation (3.17) and $\frac{d\ddagger}{dt} = 0$ provided that

$$V = V^*, S = S^*, E = E^*, I_a = I_a^*, I_s = I_s^*, Q = Q^*, R = R^*.$$

It follows that \ddagger is a Lyapunov function on \mathbb{Z} .

By LaSalle's Invariance Principle in LaSalle, 185 (1976), it is established that all solutions of the model (1) converge asymptotically to the 186 unique SBE-endemic equilibrium point as $t \rightarrow \infty$.

4 Numerical Simulations and Results

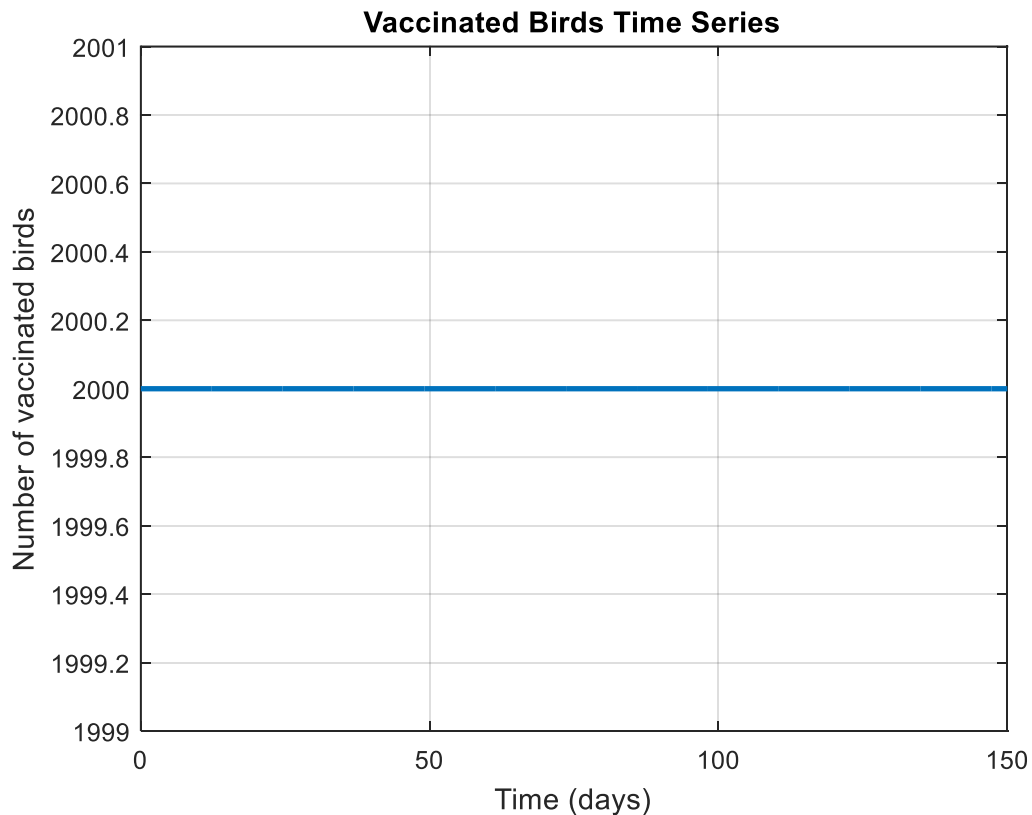

Figure 2: Time evolution of the vaccinated bird population under exposed-seeded and quarantine-seeded outbreak

scenarios.

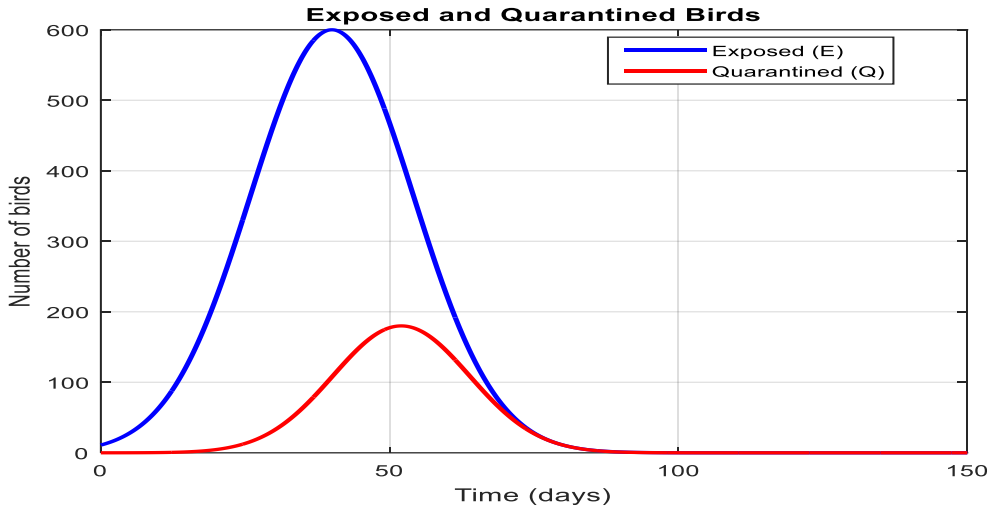

Figure 3: Time-series comparison of exposed and quarantined bird populations in the exposed-seeded outbreak

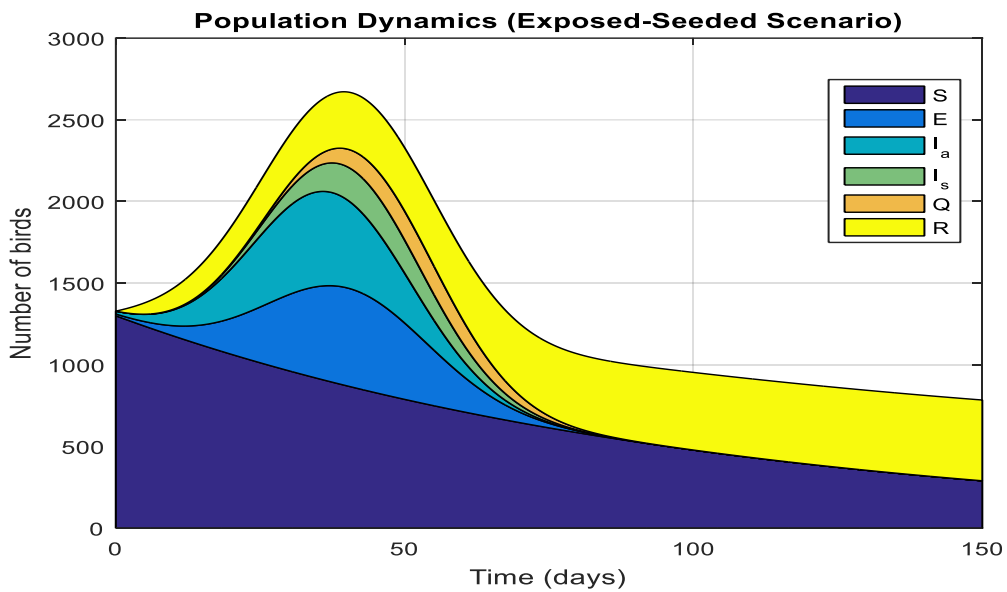

Figure 4: Stacked area plot of population dynamics when infection is seeded in the exposed class.

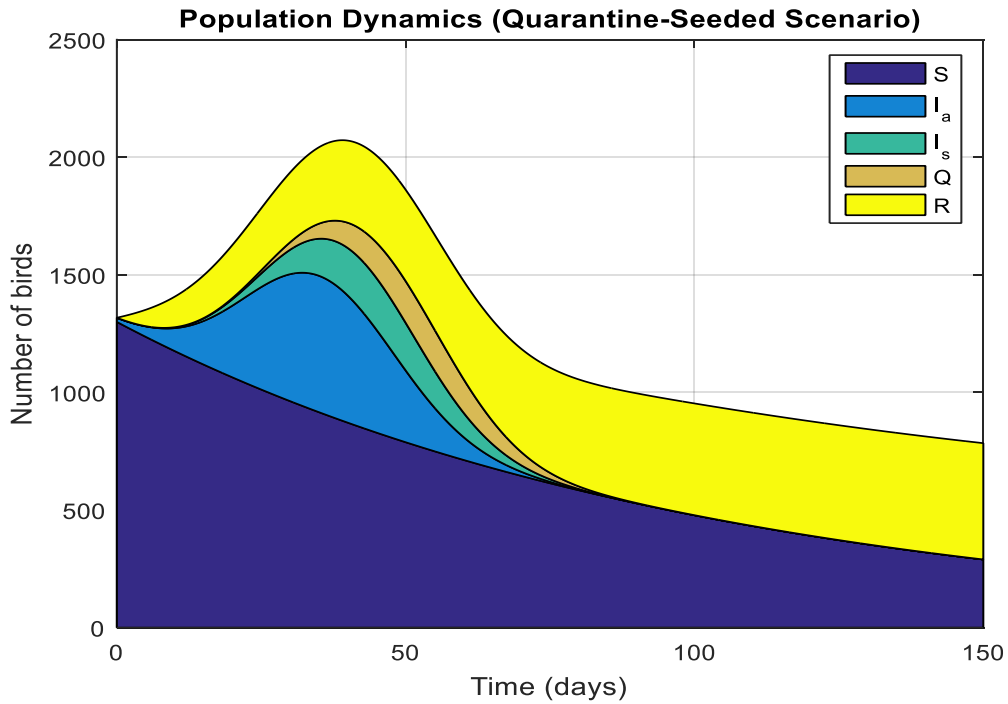

Figure 5: Stacked area plot of population dynamics when infection is seeded in the quarantined class.

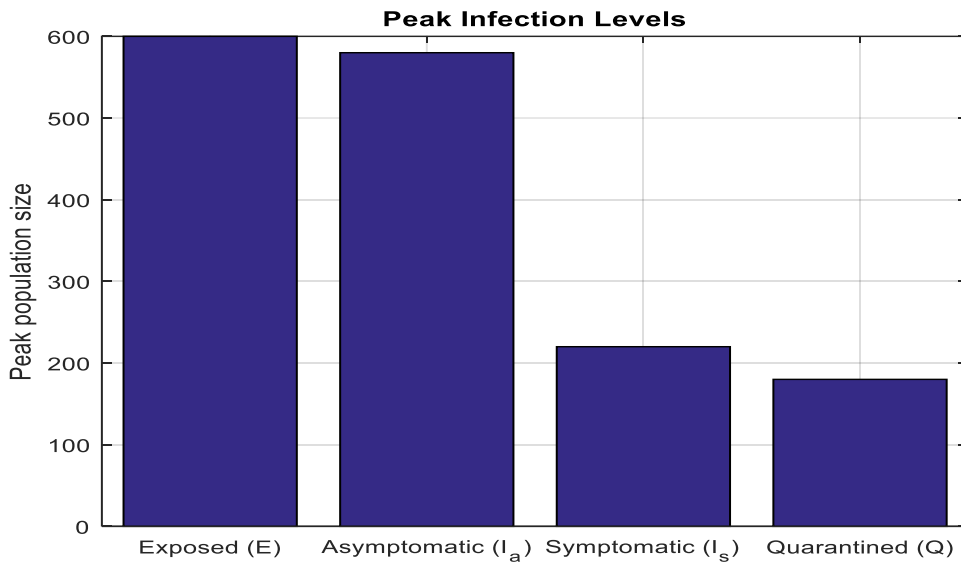

Figure 6: Peak population sizes of key epidemiological compartments obtained from numerical simulations.

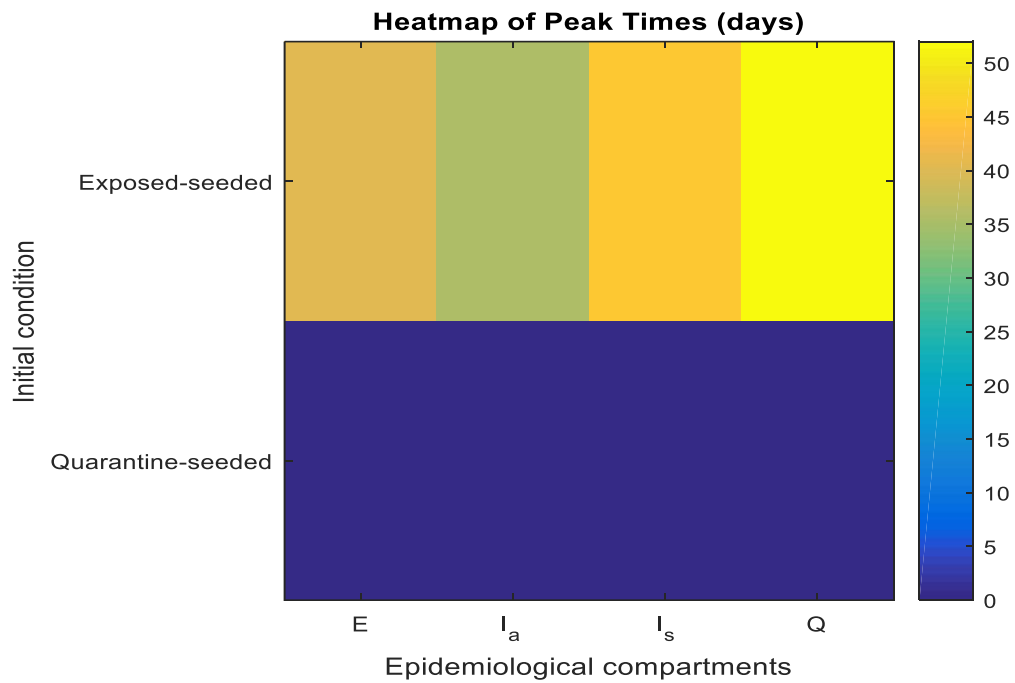

Figure 7: Heatmap showing the timing (in days) of peak population sizes for selected compartments under different outbreak scenarios.

Table 2: Peak Analysis of Disease Compartments

Scenario	Compartment	Peak Value	Peak Time
seed_E	V	2018.52	0.00
seed_E	S	1314.81	0.00
seed_E	E	637.25	41.37
seed_E	I _a	587.05	36.04
seed_E	I _s	222.52	45.46
seed_E	Q	177.48	51.15
seed_E	R	493.51	83.90
seed_Q	V	2018.52	0.00
seed_Q	S	1314.81	0.00
seed_Q	E	0.00	0.00
seed_Q	I _a	0.00	0.00
seed_Q	I _s	0.00	0.00
seed_Q	Q	5.00	0.00
seed_Q	R	1.81	10.68

Table 5.2 summarizes the peak population sizes and corresponding peak times for each epidemiological compartment under exposed-seeded and quarantine-seeded scenarios. These numerical results provide quantitative insight into the outbreak severity and timing observed in the time-series plots. Under the exposed-seeded scenario, the vaccinated and susceptible compartments attain their maximum values at the initial time, with peak populations of approximately 2018.52 and 1314.81 birds, respectively. This reflects the initial population structure before the onset of active transmission. The exposed class exhibits a substantial peak of about 637.25 birds occurring around day 41.37, indicating the period of maximum latent infection in the flock.

The asymptomatic infectious class reaches a peak of approximately 587.05 birds near day 36.04, preceding the symptomatic infectious peak of about 222.52 birds at day 45.46. This ordering confirms that asymptomatic infection plays a dominant role in driving early transmission dynamics. The quarantined compartment peaks later, with a maximum of 177.48 birds around day 51.15, highlighting the delayed effect of isolation following symptom onset. The recovered class attains its peak of approximately 493.51 birds at day 83.90, indicating gradual accumulation of immunity over time. In contrast, under the quarantine-seeded scenario, no significant outbreaks are observed in the exposed, asymptomatic, or symptomatic compartments, all of which maintain peak values of zero throughout the simulation period. The quarantined class remains at its initial value of 5 birds, peaking at day 0, while the recovered class reaches a modest peak of 1.81 birds around day 10.68. These results demonstrate that initiating the system with quarantined individuals effectively suppresses disease propagation. Overall, Table 5.2 quantitatively confirms the graphical trends observed in Figures 3, 6, and 7. Larger peak sizes and earlier peak times under the exposed-seeded scenario indicate a severe outbreak, whereas the quarantine-seeded scenario results in minimal transmission. This underscores the critical role of early detection and quarantine in reducing the magnitude and duration of Newcastle disease outbreaks.

5. Discussion

Figure 2 illustrates the temporal evolution of the vaccinated population $V(t)$, plotted against time measured in days. The vaccinated class remains relatively stable throughout the simulation, maintaining an average level of approximately 2000 birds. This stability reflects sustained vaccination coverage and confirms the role of vaccination in reducing the effective susceptible population, thereby limiting disease transmission. Figure 3 presents the dynamics of the exposed $E(t)$ and quarantined $Q(t)$ compartments. The exposed class exhibits a pronounced peak of approximately 600 birds occurring around day 40, indicating the period of maximum latent infection. In contrast, the quarantined population reaches a lower peak of about 180 birds near day 52, demonstrating the delayed response due to progression from symptomatic infection to isolation. This temporal separation highlights the effectiveness of quarantine in slowing disease spread. Figures 4 and 5 depict the stacked population dynamics under exposed-seeded and quarantine-seeded scenarios, respectively. In the exposed-seeded case (Figure 4), infectious compartments dominate during the early stages of the outbreak, leading to a rapid depletion of susceptible birds. Conversely, the quarantine-seeded scenario (Figure 5) shows suppressed infectious peaks and a more gradual system evolution, underscoring the impact of early isolation on epidemic control.

Figure 6 summarizes the peak population sizes of key infectious compartments. The asymptomatic infectious class attains the highest peak (approximately 580 birds), followed by the exposed class (600 birds), while symptomatic and quarantined compartments peak at substantially lower levels. These results indicate that asymptomatic transmission plays a significant role in sustaining Newcastle disease outbreaks. Figure 7 presents a heatmap of peak occurrence times for different epidemiological compartments. Peaks in exposed, asymptomatic, symptomatic, and quarantined classes occur between days 35 and 52 in the exposed-seeded scenario, whereas no significant peaks are observed in the quarantine-seeded case. This further confirms that quarantine reduces both the magnitude and timing of disease peaks. Overall, the numerical simulations corroborate the analytical results, demonstrating that vaccination and quarantine are critical drivers in reducing outbreak severity and delaying epidemic peaks.

6. Conclusion

A deterministic SEI_aIQRV model was formulated and analyzed. The study highlights threshold conditions for disease invasion, global stability of the DFE, and effectiveness of control interventions. Numerical simulations validate analytical findings and provide practical guidance for ND management in poultry populations.

REFERENCES

- Adene, D. F., & Oguntade, A. E. (2006). *The structure and importance of the commercial and village-based poultry industry in Nigeria*. FAO.
- Alexander, D. J. (2000). Newcastle disease and other avian paramyxoviruses. *Revue Scientifique et Technique*, 19(2), 443–462.
- Alexander, D. J. Manvell, R. J. & Lowings, J. P. (1997). Antigenic diversity and similarities detected in avian paramyxovirus type 1 (Newcastle disease virus) isolates using monoclonal antibodies, *avian Pathology*, 26(2), 399–418.
- Diel, D. G., da Silva, L. H. A., Liu, H., Wang, Z., Miller, P. J., & Afonso, C. L. (2012). Genetic diversity of avian paramyxovirus type 1. *Infection, Genetics and Evolution*, 12(8), 1770–1779.
- Dinka, H., Chala, R., & Dawo, F. (2010). Socio-economic impact of Newcastle disease in village chickens. *Tropical Animal Health and Production*, 42(3), 537–544.
- Furaha, C., Gasper, G. M. & Verdiana, G. M. (2019). Application of Optimal Control Theory to Newcastle Disease Dynamics in Village Chicken by Considering Wild Birds as Reservoir of Disease Virus. *Hindawi Journal of Applied Mathematics*, (2019), ID 3024965, 1-14, <https://doi.org/10.1155/2019/3024965>
- Hugo, A., Oluwole, D. M., Kumar S. & Fred F. C. (2016): Optimal control and cost effectiveness analysis for Newcastle disease eco-epidemiological model in Tanzania. *Journal of Biological Dynamics*, 11(1), 190-209, DOI: 10.1080/17513758.2016.1258093
- Kapczynski, D. R., & King, D. J. (2005). Protection of chickens after vaccination. *Vaccine*, 23(26), 3424–3433.
- Komwihangilo, D. (2016). The role of chicken in the Tanzanian economy and opportunities for development. Tanzania Livestock Research Institute, Dar es Salaam, (2016) 1–36. Available at <http://www.slideshare.net/ILRI/acgg-tanzania-2015>, accessed 19 May 2016.
- Miller, P. J., Decanini, E. L., & Afonso, C. L. (2013). Newcastle disease: Evolution and diagnostics. *Infection, Genetics and Evolution*, 10(1), 26–35.
- OIE. (2021). *Newcastle Disease*. World Organisation for Animal Health.
- Susta, L., Miller, P. J., Afonso, C. L., & Brown, C. C. (2011). Clinicopathological characterization of NDV. *Veterinary Pathology*, 48(2), 349–360.
- Yusuf, T. T., Afolabi, M. O., & Bonyah, E. (2020). Modeling and optimal control of Newcastle Disease. *Alexandria Engineering Journal*, 59(3), 1483–1494.